

“O-RING SEAL”

T A P E R E D P I P E T H R E A D

“O-RING SEAL”

400 • Male Elbow

Part No.	Tube O.D.	Male Pipe Thread	“A” (Tube Leg)	“C” Male Pipe Leg
400-2-2	1/8"	1/8"	25/32"	25/32"
400-4-2	1/4"	1/8"	1"	25/32"
400-4-4	1/4"	1/4"	1 1/16"	1 3/32"
400-5-2	5/16"	1/8"	1 1/32"	25/32"
400-5-4	5/16"	1/4"	1 1/32"	1 3/32"
400-6-4	3/8"	1/4"	1 1/8"	1 3/32"
400-6-2	3/8"	1/8"	1 1/8"	7/8"
400-6-6	3/8"	3/8"	1 3/16"	1 7/32"
400-6-8	3/8"	1/2"	1 1/4"	1 15/32"
400-8-6	1/2"	3/8"	1 15/32"	1 7/32"
400-8-4	1/2"	1/4"	1 15/32"	1 5/32"
400-8-8	1/2"	1/2"	1 15/32"	1 15/32"
400-8-12	1/2"	3/4"	1 19/32"	1 9/16"
400-10-8	5/8"	1/2"	1 21/32"	1 15/32"
400-10-4	5/8"	1/4"	1 21/32"	1 5/16"
400-10-6	5/8"	3/8"	1 21/32"	1 3/8"
400-10-12	5/8"	3/4"	1 23/32"	1 19/32"
400-12-12	3/4"	3/4"	1 23/32"	1 19/32"
400-12-8	3/4"	1/2"	1 27/32"	1 9/16"
400-14-12	7/8"	3/4"	1 15/16"	1 11/16"
400-16-16	1"	1"	2 7/32"	1 31/32"
400-16-12	1"	3/4"	2 7/32"	1 23/32"
400-18-16	1 1/8"	1"	2 13/32"	2 1/8"
400-20-20	1 1/4"	1 1/4"	2 19/32"	2 3/8"
400-20-16	1 1/4"	1"	2 19/32"	2 3/8"
400-20-24	1 1/4"	1 1/2"	2 23/32"	2 5/8"
400-24-24	1 1/2"	1 1/2"	2 29/32"	2 5/8"
400-24-20	1 1/2"	1 1/4"	2 29/32"	2 5/8"
400-32-32	2"	2"	3 19/32"	3"
400-32-24	2"	1 1/2"	3 19/32"	3"

400 MALE ELBOW • TUBE END - MALE PIPE END

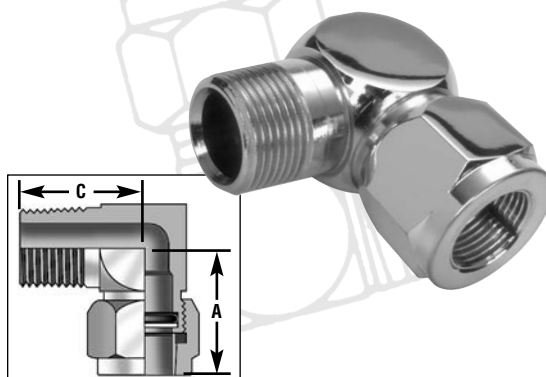

400-L LONG MALE ELBOW TUBE END - MALE PIPE END

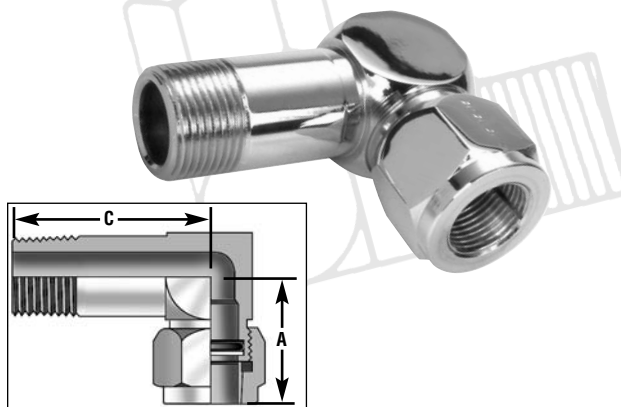

400-L • Long Male Elbow

Part No.	Tube O.D.	Male Pipe Thread	“A” (Tube Leg)	“C” (Male Pipe Leg)
400L-4-2	1/4"	1/8"	1"	1 3/16"
400L-5-2	5/16"	1/8"	1 1/32"	1 1/4"
400L-6-4	3/8"	1/4"	1 1/8"	1 21/32"
400L-8-6	1/2"	3/8"	1 15/32"	1 27/32"
400L-10-8	5/8"	1/2"	1 21/32"	2 7/32"
400L-12-12	3/4"	3/4"	1 27/32"	2 15/32"
400L-14-12	7/8"	3/4"	1 15/16"	2 23/32"
400L-16-16	1"	1"	2 7/32"	3 1/16"
400L-20-20	1 1/4"	1 1/4"	2 19/32"	3 11/16"

400-LL EXTRA LONG MALE ELBOW TUBE END - MALE PIPE END

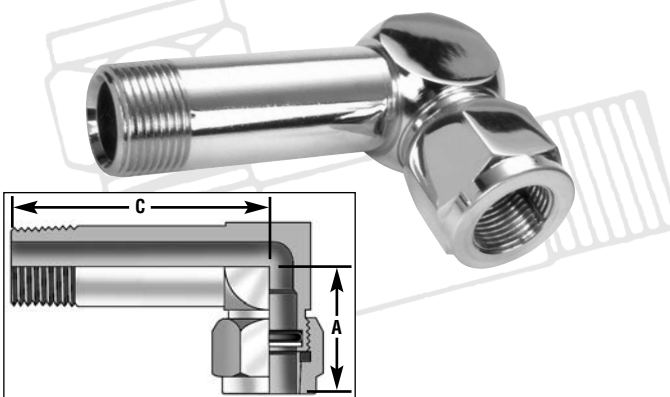

400-LL • Extra Long Male Elbow

Part No.	Tube O.D.	Male Pipe Thread	“A” (Tube Leg)	“C” (Male Pipe Leg)
400LL-4-2	1/4"	1/8"	1"	1 17/32"
400LL-5-2	5/16"	1/8"	1 1/32"	1 5/8"
400LL-6-4	3/8"	1/4"	1 1/8"	2 3/32"
400LL-8-6	1/2"	3/8"	1 15/32"	2 1/2"
400LL-10-8	5/8"	1/2"	1 21/32"	3"
400LL-12-12	3/4"	3/4"	1 27/32"	3 11/32"
400LL-14-12	7/8"	3/4"	1 15/16"	3 5/8"
400LL-16-16	1"	1"	2 7/32"	4 3/16"
400LL-20-20	1 1/4"	1 1/4"	2 19/32"	4 7/8"

Note: 400LL Elbows will turn above 400 Elbows & 400LLL Elbows will turn above 400LL Elbows

Stainless Steel Tubing

Lenz O-ring Seal tube fitting performs equally well on stainless steel tubing as with carbon steel tubing, but requires the use of stainless steel sleeves (#165-xxSS) and stainless steel buffer washers (#195-xx-SS), even when used with steel fittings. Example, when ordering: 100-12-12 with ss sleeves. When Ordering Lenz Fittings in all Stainless Steel Add SS To The Part Number. Example: 100-12-12-SS

TUBING

(SPECIFICATIONS & IDENTIFICATION)

LENZ HYDRAULIC STEEL TUBING Dead Soft • Fully Annealed • Bright Finish

Superior grade tubing selected for excellence of bending and flaring. The formula given below is determined with the flow calculated to give nominal pressure drop through tubing having the diameter and wall thickness as indicated in the table to left. This flow is based on a velocity of 15 feet per second and fluids having a maximum viscosity of 315 S.S.U.

Formula

$$GPM = \frac{\pi D^2 \times 15}{1.283} = 36.69 \times D^2$$

*D = Inside Diameter of Tubing

Furnished in 12 Ft. Lengths-Longer Lengths On Request.
**Safety Factor of 5 means that the tubing will burst at 5 times the working pressure indicated.

Lenz Hydraulic Steel Tubing

Size No.	O.D.	I.D.	Wall Thickness	G.P.M. Flow	Working Pressure
4.035	1/4"	.180	.035	1.2	2800
4.049	1/4"	.152	.049	.85	3920
5.035	5/16"	.242	.035	2.15	2240
5.049	5/16"	.214	.049	1.68	3136
6.035	3/8"	.305	.035	3.45	1867
6.049	3/8"	.277	.049	2.82	2613
6.065	3/8"	.245	.065	2.2	3467
8.035	1/2"	.430	.035	6.79	1400
8.049	1/2"	.402	.049	5.92	1960
8.065	1/2"	.370	.065	5.03	2600
10.049	5/8"	.527	.049	10.2	1568
10.065	5/8"	.495	.065	9.0	2080
10.095	5/8"	.435	.095	6.94	3040
12.049	3/4"	.652	.049	15.6	1307
12.065	3/4"	.620	.065	14.1	1733
12.095	3/4"	.560	.095	11.5	2533
12.109	3/4"	.532	.109	10.4	2907
14.049	7/8"	.777	.049	22.1	1120
14.065	7/8"	.745	.065	20.4	1486
14.095	7/8"	.685	.095	17.2	2171
16.065	1"	.870	.065	27.8	1300
16.095	1"	.810	.095	24.1	1900
16.120	1"	.760	.120	21.2	2400
20.065	1 1/4"	1.120	.065	46.0	1040
20.095	1 1/4"	1.060	.095	41.2	1520
20.120	1 1/4"	1.010	.120	37.4	1920
24.095	1 1/2"	1.310	.095	63.0	1267
24.120	1 1/2"	1.260	.120	58.1	1600

PCC LENZ S.A.E. PORT CONTOUR CUTTERS

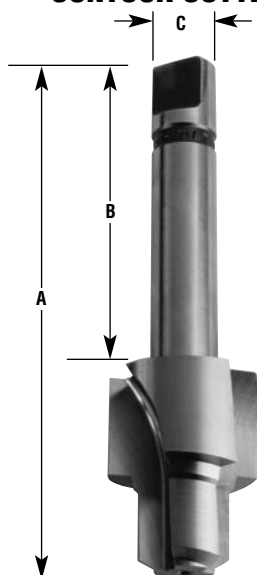

PCT LENZ PRECISION S.A.E. PORT THREAD TAPS



These tools have three flutes which form the standard internal O-Ring Boss for straight thread tube fittings. Standard in high-speed steel. Carbide tipped available on special order. Four flute cutters available on special order.

PCC-LENZ S.A.E. Port Contour Cutter

Part No.	Tube O.D.	Thread Size	"A" Overall Length	"B" Shank Length	"C" Shank Dia.
PCC-2	1/8"	5/16"-24	3 ²³ / ₃₂ "	2 ¹¹ / ₆₄ "	.500
PCC-4	1/4"	7/16"-20	3 ²⁵ / ₃₂ "	2 ⁵ / ₃₂ "	.500
PCC-5	5/16"	1/2"-20	3 ²⁷ / ₃₂ "	2 ⁷ / ₃₂ "	.500
PCC-6	3/8"	9/16"-18	3 ²⁹ / ₃₂ "	2 ⁵ / ₆₄ "	.500
PCC-8	1/2"	3/4"-16	3 ³¹ / ₃₂ "	2 ¹ / ₁₆ "	.500
PCC-10	5/8"	7/8"-14	3 ³¹ / ₃₂ "	1 ⁵³ / ₆₄ "	.750
PCC-12	3/4"	1 1/16"-12	4 1/8"	1 ⁵⁵ / ₆₄ "	.750
PCC-14	7/8"	1 3/16"-12	4 1/8"	1 ²⁷ / ₃₂ "	.750
PCC-16	1"	1 5/16"-12	4 1/8"	1 ²⁷ / ₃₂ "	.750
PCC-20	1 1/4"	1 5/8"-12	4 1/8"	1 ⁵³ / ₆₄ "	1.000
PCC-24	1 1/2"	1 7/8"-12	4 1/8"	1 ¹³ / ₁₆ "	1.000
PCC-32	2"	2 1/2"-12	4 1/4"	1 ²⁹ / ₃₂ "	1.000

PCT • LENZ Precision S.A.E. Port Thread Taps

Part Number	Tube O.D.	Thread Size
PCT-2	1/8"	5/16"-24
PCT-4	1/4"	7/16"-20
PCT-5	5/16"	1/2"-20
PCT-6	3/8"	9/16"-18
PCT-8	1/2"	3/4"-16
PCT-10	5/8"	7/8"-14
PCT-12	3/4"	1 1/16"-12
PCT-14	7/8"	1 3/16"-12
PCT-16	1"	1 5/16"-12
PCT-20	1 1/4"	1 5/8"-12
PCT-24	1 1/2"	1 7/8"-12
PCT-32	2"	2 1/2"-12